



**BUILDING CODE COMPLIANCE OFFICE (BCCO)  
PRODUCT CONTROL DIVISION  
NOTICE OF ACCEPTANCE (NOA)**

**MIAMI-DADE COUNTY, FLORIDA  
METRO-DADE FLAGLER BUILDING  
140 WEST FLAGLER STREET, SUITE 1603  
MIAMI, FLORIDA 33130-1563  
(305) 375-2901 FAX (305) 372-6339  
[www.miamidade.gov/buildingcode](http://www.miamidade.gov/buildingcode)**

**Arrow United Industries  
314 Riverside Drive  
Wyalusing, PA 18853**

**SCOPE:**

This NOA is being issued under the applicable rules and regulations governing the use of construction materials. The documentation submitted has been reviewed by Miami-Dade County Product Control Division and accepted by the Board of Rules and Appeals (BORA) to be used in Miami Dade County and other areas where allowed by the Authority Having Jurisdiction (AHJ).

This NOA shall not be valid after the expiration date stated below. The Miami-Dade County Product Control Division (In Miami Dade County) and/or the AHJ (in areas other than Miami Dade County) reserve the right to have this product or material tested for quality assurance purposes. If this product or material fails to perform in the accepted manner, the manufacturer will incur the expense of such testing and the AHJ may immediately revoke, modify, or suspend the use of such product or material within their jurisdiction. BORA reserves the right to revoke this acceptance, if it is determined by Miami-Dade County Product Control Division that this product or material fails to meet the requirements of the applicable building code.

This product is approved as described herein, and has been designed to comply with the Florida Building Code, including the High Velocity Hurricane Zone.

**DESCRIPTION: Model EAV-81 8" deep Aluminum Louver**

**APPROVAL DOCUMENT:** Drawing No. 1624, titled "Model EAV-81 Impact Louver System", sheets 1 through 3 of 3, dated 11/12/08, prepared by W. W. Schaefer Engineering & Consulting, P.A., signed and sealed by Warren. W. Schaefer, P.E., bearing the Miami-Dade County Product Control Approval stamp with the Notice of Acceptance number and Approval date by the Miami-Dade County Product Control Division.

**MISSILE IMPACT RATING: Large and Small Missile Impact Resistant**

**LABELING:** Each unit shall bear a permanent label with the manufacturer's name or logo, city, state and following statement: "Miami-Dade County Product Control Approved", unless otherwise noted herein.

**RENEWAL** of this NOA shall be considered after a renewal application has been filed and there has been no change in the applicable building code negatively affecting the performance of this product.

**TERMINATION** of this NOA will occur after the expiration date or if there has been a revision or change in the materials, use, and/or manufacture of the product or process. Misuse of this NOA as an endorsement of any product, for sales, advertising or any other purposes shall automatically terminate this NOA. Failure to comply with any section of this NOA shall be cause for termination and removal of NOA.

**ADVERTISEMENT:** The NOA number preceded by the words Miami-Dade County, Florida, and followed by the expiration date may be displayed in advertising literature. If any portion of the NOA is displayed, then it shall be done in its entirety.

**INSPECTION:** A copy of this entire NOA shall be provided to the user by the manufacturer or its distributors and shall be available for inspection at the job site at the request of the Building Official.

This NOA consists of this page 1 and evidence page E-1, as well as approval document mentioned above.

The submitted documentation was reviewed by **Carlos M. Utrera, P.E.**



*Utrera*  
1/12/09

**NOA No. 08-1202.08  
Expiration Date: February 4, 2014  
Approval Date: February 4, 2009  
Page 1**

**NOTICE OF ACCEPTANCE: EVIDENCE SUBMITTED**

**A. DRAWINGS**

1. Drawing No. **1624**, titled "Model EAV-81 Impact Louver System", sheets 1 through 3 of 3, dated 11/12/08, prepared by W. W. Schaefer Engineering & Consulting, P.A., signed and sealed by Warren W. Schaefer, P.E.

**B. TESTS**

1. Test reports on: 1) Uniform Static Air Pressure Test, Loading per FBC TAS 202-94  
2) Large Missile Impact Test per FBC, TAS 201-94 and ASTM E1886/1996 Level E.  
3) Cyclic Wind Pressure per FBC, TAS 203-94 and ASTM E1886/1996.  
along with marked-up drawings and installation diagram, of their A-820 Aluminum Louver System", prepared by Hurricane Test Laboratory, Inc., Report No. **0198-0812-08**, dated 10/14/08, signed and sealed by Vinu J. Abraham, P.E.
2. Test report on Wind and Wind-Driven Rain Resistance per TAS 100(A)-95 of their A-820 Louver, prepared by PRI Construction Materials Technologies, LLC, and Report No. **009-02-02**, dated 04/28/08, signed and sealed by Duc T. Nguyen, P.E.

**C. CALCULATIONS**

1. Anchoring calculations prepared by W.W. Schaefer Engineering & Consulting, P.A., dated 11/24/08, signed and sealed by Warren W. Schaefer, P.E.

**D. QUALITY ASSURANCE**

1. Miami Dade Building Code Compliance Office (BCCO).

**E. MATERIAL CERTIFICATIONS**

1. None.

**F. STATEMENTS**

1. Code compliance letter issued by W. W. Schaefer Engineering & Consulting, P.A., dated 11/24/08, signed and sealed by Warren W. Schaefer, P.E.
2. No financial interest letter issued by W. W. Schaefer Engineering & Consulting, P.A., dated 11/24/08, signed and sealed by Warren W. Schaefer, P.E.
3. Test code compliance letter issued by Hurricane Test Laboratory, Inc., dated 10/14/08, signed and sealed by Vinu J. Abraham, P.E.

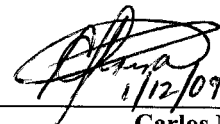

1/12/09

Carlos M. Utrera, P.E.  
Product Control Examiner  
NOA No. 08-1202.08

Expiration Date: February 4, 2014  
Approval Date: February 4, 2009

**GENERAL NOTES:**

1. THESE LOUVER SYSTEMS HAVE BEEN TESTED, ANALYZED & APPROVED FOR DESIGN PRESSURES NOT TO EXCEED THOSE SHOWN IN THE "ALLOWABLE DESIGN PRESSURE TABLE(S)".
2. OPENINGS, BUCKING & BUCKING FASTENERS MUST BE PROPERLY DESIGNED & INSTALLED TO TRANSFER WIND LOADS TO THE STRUCTURE. IT SHALL BE THE RESPONSIBILITY OF THE PERMIT HOLDER TO VERIFY THE STRUCTURAL INTEGRITY OF THE EXISTING STRUCTURE TO SUPPORT THE LOADS SUPERIMPOSED BY THE LOUVERS.
3. ALL HARDWARE & FASTENERS SHALL BE IN ACCORDANCE WITH THESE DRAWINGS & SHALL NOT VARY UNLESS SPECIFICALLY MENTIONED ON THE DRAWINGS. SPECIFIED ANCHOR EMBED TO BASE MATERIAL SHALL BE BEYOND WALL FINISH OR STUCCO.
4. THE DETAILS & SPECIFICATIONS SHOWN HEREIN REPRESENT THE PRODUCTS TESTED & PROPOSED FOR WATER, AIR, IMPACT, CYCLIC & UNIFORM STATIC AIR PRESSURE TESTING IN CONFORMANCE WITH THE FLORIDA BUILDING CODE PROTOCOLS TAS-101, 201, 202 & 203 FOR LARGE MISSILE IMPACT LOUVERS & ASTM E1886 & E1996 FOR ESSENTIAL FACILITIES LEVEL "E" 80 FT/S LARGE MISSILE IMPACT SPEED. THEREFORE, THESE LOUVER SYSTEMS ARE APPROVED FOR USE WITH ESSENTIAL FACILITIES.
5. THESE LOUVER SYSTEMS HAVE BEEN DESIGNED IN ACCORDANCE WITH AND MEET THE REQUIREMENTS OF THE FLORIDA BUILDING CODE (FBC) INCLUDING HIGH VELOCITY HURRICANE ZONES (HVHZ).
6. IMPACT SHUTTERS ARE NOT REQUIRED WITH THESE LOUVERS.
7. ALL ANCHORS SECURING FRAME TO PRESSURE TREATED BUCKS OR WOOD FRAMING SHALL BE CAPABLE OF RESISTING CORROSION CAUSED BY THE PRESSURE TREATING CHEMICALS IN THE WOOD.
8. DETERMINE THE POSITIVE & NEGATIVE DESIGN LOADS TO USE WHEN REFERENCING THESE DOCUMENTS IN ACCORDANCE WITH THE GOVERNING CODE AND GOVERNING WIND VELOCITY. FOR WIND LOAD CALCULATIONS IN ACCORDANCE WITH THE FLORIDA BUILDING CODE, A DIRECTIONALITY FACTOR OF  $K_d = 0.85$  MAY BE APPLIED WHEN USED IN CONJUNCTION WITH LOAD COMBINATIONS SPECIFIED IN SECTION 2.0 OF THE ASCE 7 STANDARD.
9. NO INCREASE IN ALLOWABLE STRESS HAS BEEN USED IN THE CERTIFICATION OF THIS PRODUCT. WIND LOAD DURATION FACTOR  $C_d = 1.6$  WAS USED FOR WOOD SCREW ANALYSIS ONLY.
10. MATERIALS, INCLUDING BUT NOT LIMITED TO STEEL SCREWS, THAT COME INTO CONTACT WITH OTHER DISSIMILAR MATERIALS SHALL MEET THE REQUIREMENTS OF FLORIDA BUILDING CODE CHAPTER 20.
11. EACH LOUVER ASSEMBLY SHALL BE PERMANENTLY LABELED AS FOLLOWS:  
ARROW UNITED INDUSTRIES  
WYALUSING, PA  
MIAMI-DADE COUNTY PRODUCT CONTROL APPROVED
12. THIS SYSTEM HAS BEEN TESTED FOR WATER INFILTRATION RESISTANCE AND IS A WATER RESISTANT SYSTEM.
13. INDIVIDUAL PANEL WIDTHS ARE UNLIMITED IN DIMENSION. PANEL HEIGHTS ARE LIMITED BY THE DIMENSIONS SHOWN IN THE ELEVATIONS.

**CORNER & BLADE END CONSTRUCTION:**

**FRAME:** THE HORIZONTAL FRAME MEMBERS RUN THROUGH WHILE THE VERTICAL MEMBERS ARE MITER CUT, BUTTED & SECURED WITH A CONTINUOUS WELD ALONG THE CORNER SEAM.  
**EXTERIOR BLADE:** THE BLADE IS SQUARE CUT & SECURED TO THE SILL VIA A 1/8" X 1 1/4" LONG WELD. FOR LOCATIONS SEE DETAILS B/2 & C/2  
**INTERIOR BLADE:** THE BLADE IS SQUARE CUT & SECURED TO THE FRAME VIA A SLIP FIT PROCESS WHERE THE BLADE IS SANDWICHED BETWEEN THE "Z" & "L" BLADE COMBS.

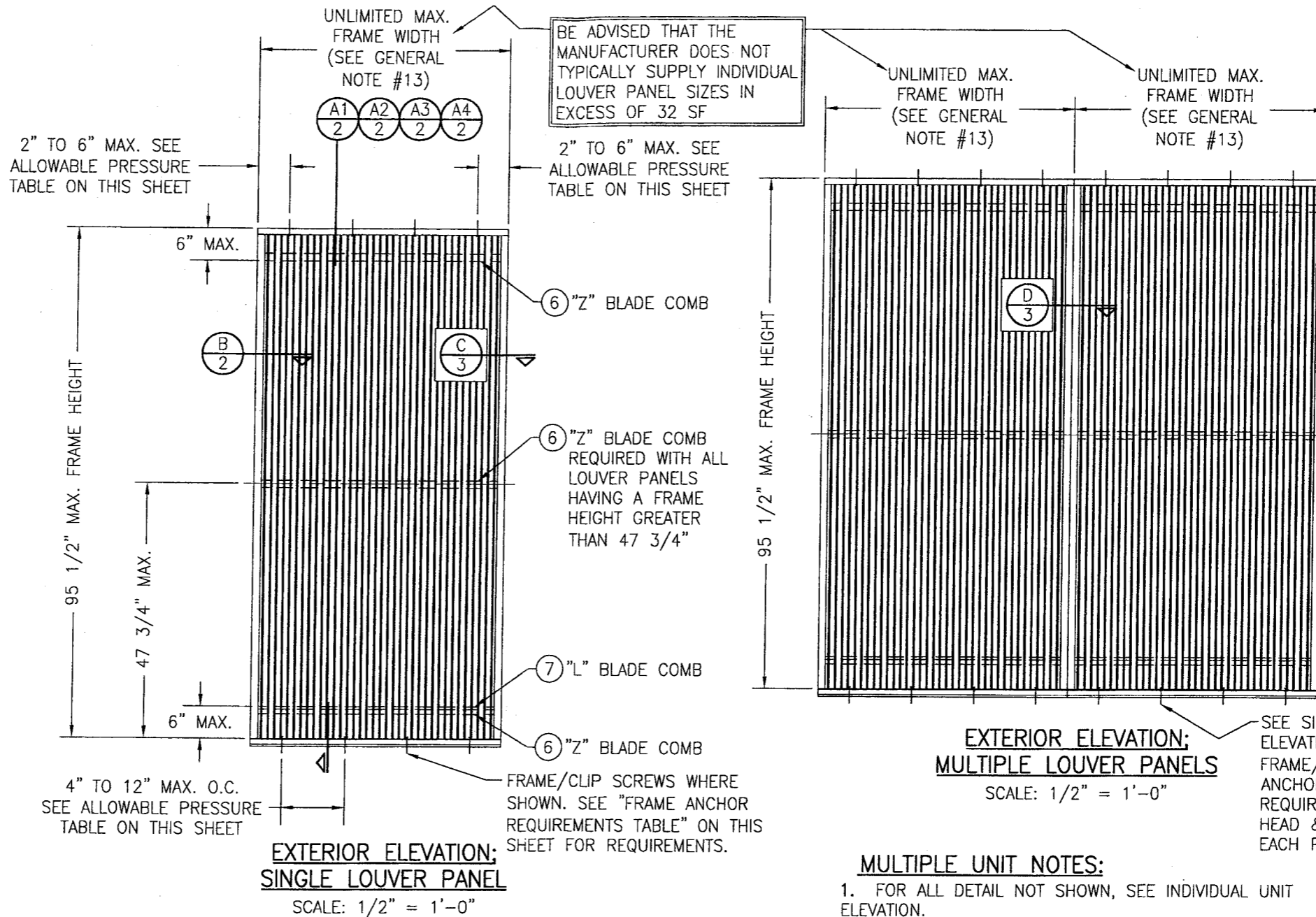

- MULTIPLE UNIT NOTES:**
1. FOR ALL DETAIL NOT SHOWN, SEE INDIVIDUAL UNIT ELEVATION.
  2. THERE IS NO LIMIT ON THE NUMBER OF SINGLE LOUVER PANELS THAT MAY BE COMBINED HORIZONTALLY INTO ONE OPENING PROVIDING THE OPENING IS DESIGNED TO SUPPORT ALL LOADS TRANSFERRED BY THE PANELS.
  3. INDIVIDUAL LOUVER PANEL SIZES SHALL BE RESTRICTED AS SPECIFIED IN THE SINGLE LOUVER PANEL ELEVATION.

**FRAME ANCHOR REQUIREMENTS TABLE**

FRAME/CLIP SCREWS			
OPENING TYPE (SUBSTRATE)	FRAME/CLIP TO OPENING FASTENER TYPE	MINIMUM EMBED	MINIMUM EDGE DIST.
MIN. 2X_ WOOD FRAME OR BUCK (MIN. GR. 3 & G=0.55)	MIN. NO. 10 SMS OR WOOD SCREW	1 1/4"	3/4"
MIN. 16 GA. 33 KSI METAL STUD	MIN. NO. 10 GR. 5 SELF TAP/DRILL SCREW	FULL	1/2"
MIN. 1/8" THK A36 STEEL	MIN. NO. 10 GR. 5 SELF TAP/DRILL SCREW OR 1/4" BOLT (1)	FULL	1/2"
MIN. 1/8" THK 6063-T5 ALUM.	MIN. NO. 10 GR. 5 SELF TAP/DRILL SCREW	FULL	1/2"
3000 PSI CONCRETE	(2) 1/4" CONCRETE SCREW	1 1/2"	2"

(1) BOLTS SHALL BE MIN. A307 GALVANIZED OR 304 S.S. (Fv = 10,000 PSI MIN.)  
 (2) CONCRETE SCREWS SHALL BE ELCO ULTRACONS, ITW RAMSET/RED HEAD TAPCONS, HILTI KWIK-CON II OR POWERS RAWL TAPPER (HARDENED STEEL OR S.S.)

**ALLOWABLE DESIGN PRESSURE & ANCHOR SPACING REQUIREMENTS (ALL LOUVER CONDITIONS)**

MAX. ANCHOR SPACING	MAX. ANCHOR END DISTANCE	ALLOWABLE PRESSURE
4"	2"	+/-150 PSF
8"	4"	+/-75 PSF
12"	6"	+/-50 PSF

Approved in compliance with the Florida Building Code  
 Date: 02/04/2009  
 08-102.08  
 Miami-Dade Product Control  
 Division  
 Warren W. Schaefer, P.E.

**DRAWING TITLE:** EAV-81 IMPACT LOUVER SYSTEM

**MANUFACTURER:** ARROW UNITED INDUSTRIES  
 314 RIVERSIDE DRIVE  
 WYALUSING, PA 18853  
 570-746-1888

**CONSULTANTS:** W. W. SCHAEFER ENGINEERING & CONSULTING, P.A.  
 8885 N. MILITARY TRAIL, SUITE C-204  
 PALM BEACH GARDENS, FL 33410  
 PHONE: 561-775-4902 FAX: 561-775-4903

**DRAWING NO.:** 1624  
**SHEET NO.:** 1 OF 3

**CERTIFICATION:** NOV 24 2008

**DRAWN BY:** W.R.M. **CHECKED BY:** W.W.S.  
**PLOT:** 1-24 **DATE:** 11/12/08

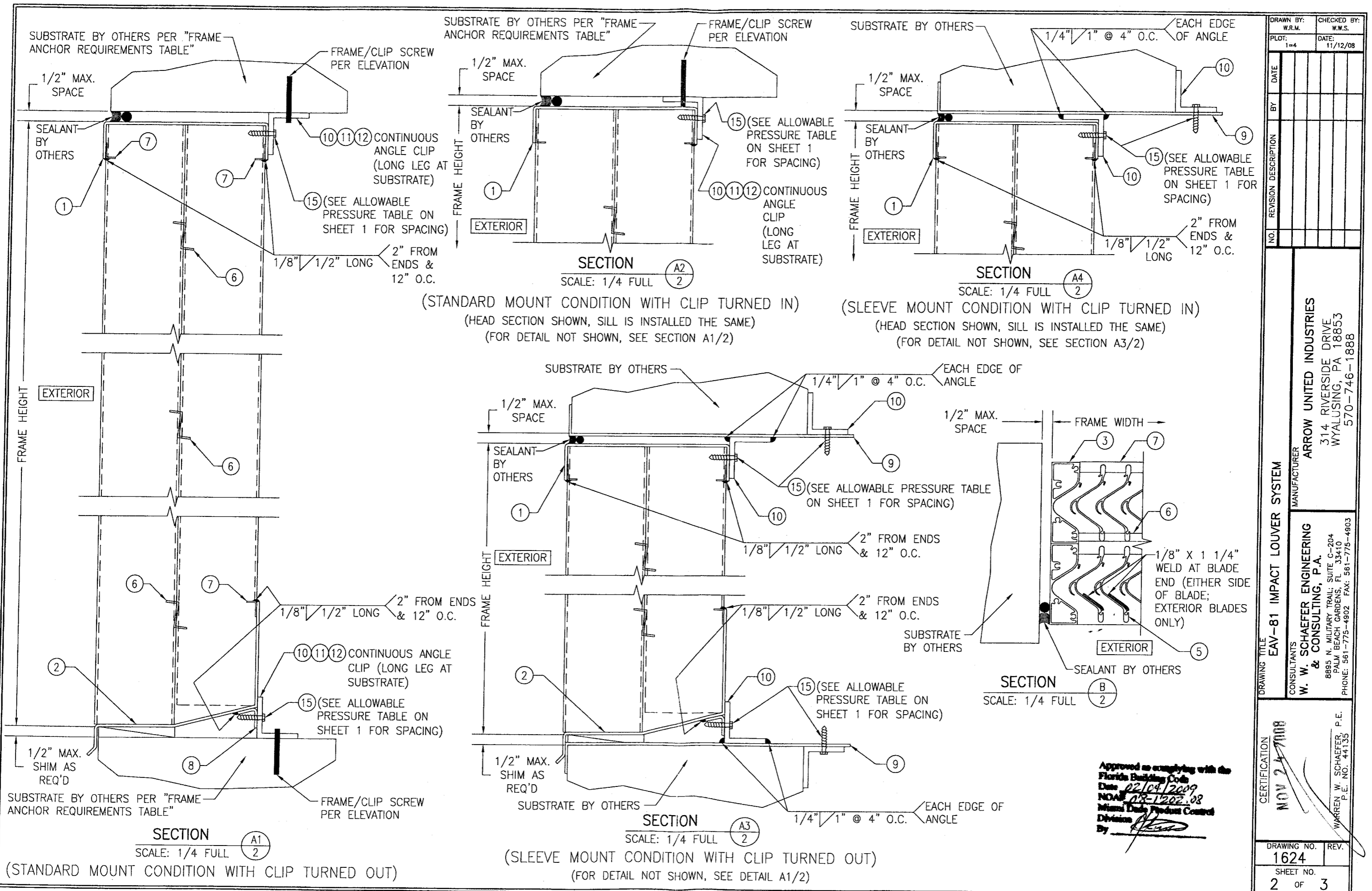

DRAWN BY:	W.R.M.	CHECKED BY:	W.W.S.
PLOT:	1=4	DATE:	11/12/08
NO.		REVISION DESCRIPTION	
DATE			
BY			

MANUFACTURER  
**ARROW UNITED INDUSTRIES**  
 314 RIVERSIDE DRIVE  
 WYALUSING, PA 18853  
 570-746-1888

CONSULTANTS  
**W. W. SCHAEFER ENGINEERING & CONSULTING, P.A.**  
 8895 N. MILITARY TRAIL, SUITE C-204  
 PALM BEACH GARDENS, FL 33410  
 PHONE: 561-775-4902 FAX: 561-775-4903

DRAWING TITLE: **EAV-81 IMPACT LOUVER SYSTEM**

CERTIFICATION: **NOV 24 2008**

APPROVED AS COMPLYING WITH THE Florida Building Code  
 Date: **02/04/2009**  
 NO. **08-1202.08**  
 Miami Dade Product Control Division  
 By: *[Signature]*

DRAWING NO.	REV.
1624	
SHEET NO.	
2	3

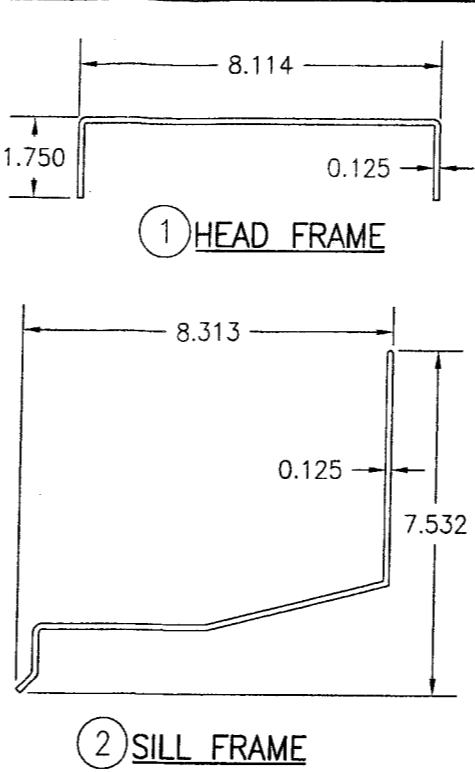
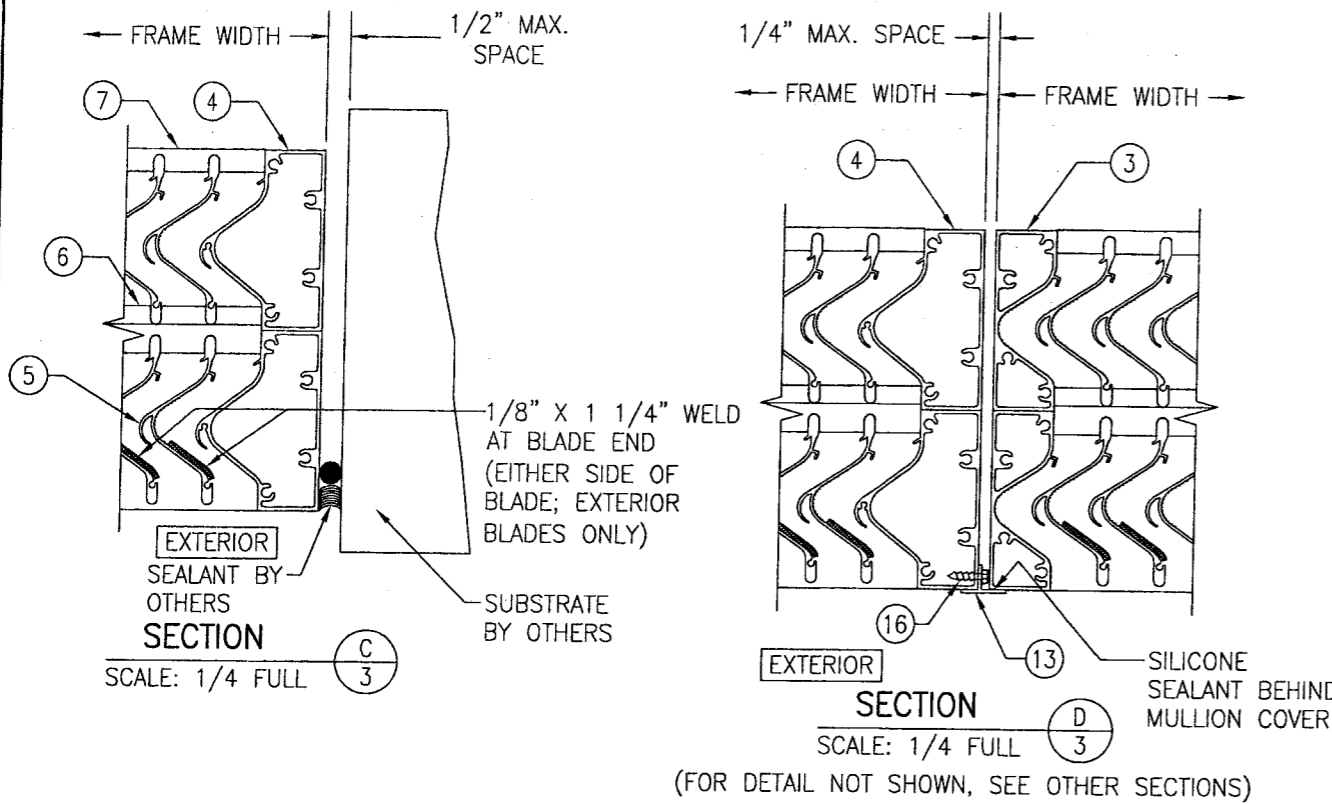

ITEM #	ITEM DESCRIPTION	MANUFACTURER/NOTES
PARTS		
1	HEAD FRAME	5052-H32 ALUMINUM
2	SILL FRAME	5052-H32 ALUMINUM
3	JAMB (FEMALE)	6063-T5 ALUMINUM
4	JAMB (MALE)	6063-T5 ALUMINUM
5	BLADE	6063-T5 ALUMINUM
6	"Z" BLADE COMB	5052-H32 ALUMINUM
7	"L" BLADE COMB	5052-H32 ALUMINUM
8	SILL MOUNTING ANGLE	5052-H32 ALUMINUM
9	MOUNTING SLEEVE	5052-H32 ALUMINUM
10	CONTINUOUS MOUNTING CLIP	6063-T5 ALUMINUM
11	CONTINUOUS MOUNTING CLIP	6063-T5 ALUMINUM
12	CONTINUOUS MOUNTING CLIP	6063-T5 ALUMINUM
13	MULLION COVER	6063-T52/T6 ALUMINUM
MISC. FASTENERS		
15	NO. 14 X 1 1/4" 410 SS TEK SCREW	FOR SPACING REQUIREMENTS SEE ALLOWABLE PRESSURE TABLE ON SHEET 1
16	NO. 8 X 3/4" 18-8 SS SMS SCREW	WITHIN 2" FROM ENDS & MAX. 15" O.C.

NO.	REVISION DESCRIPTION	DATE	BY	DATE
1				

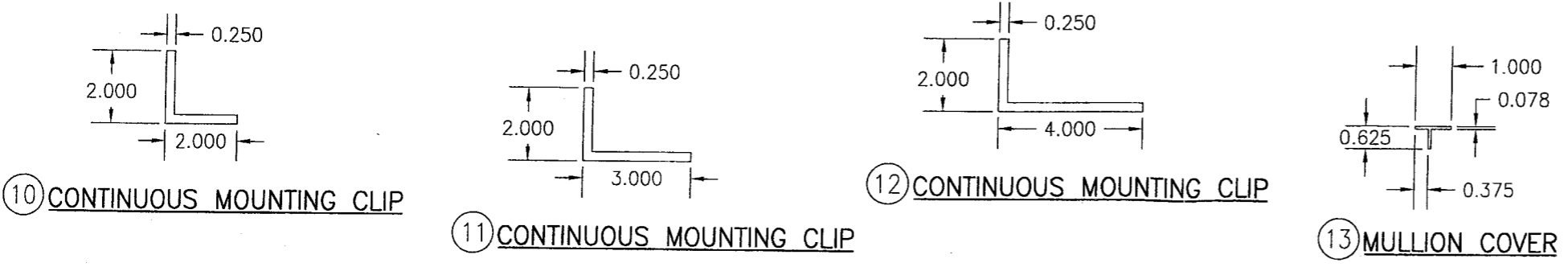
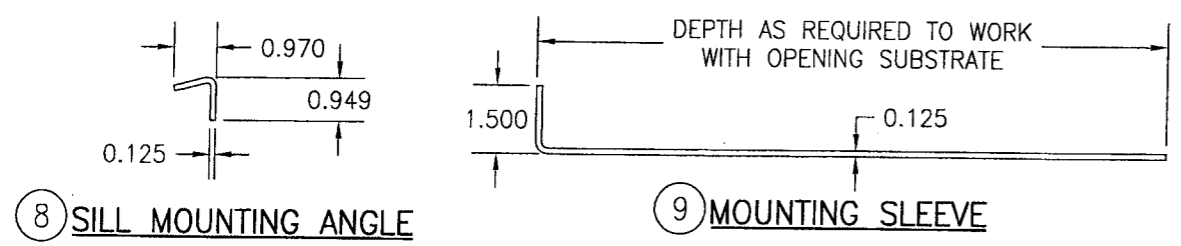
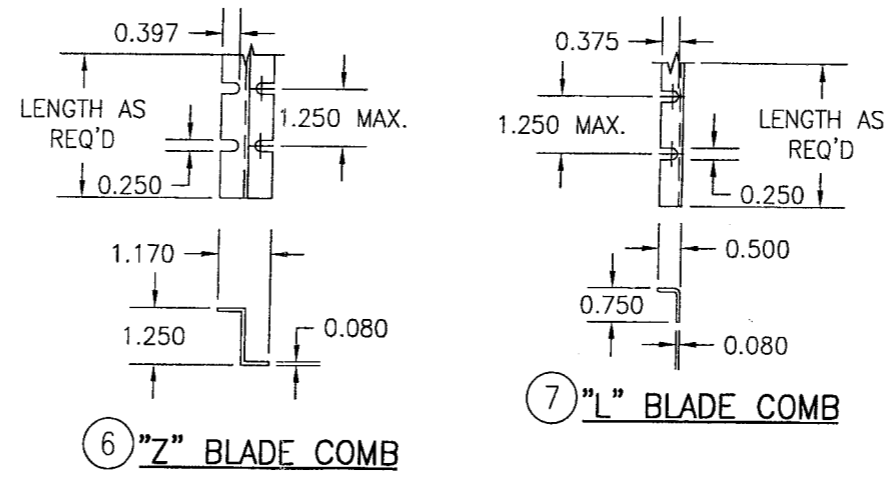
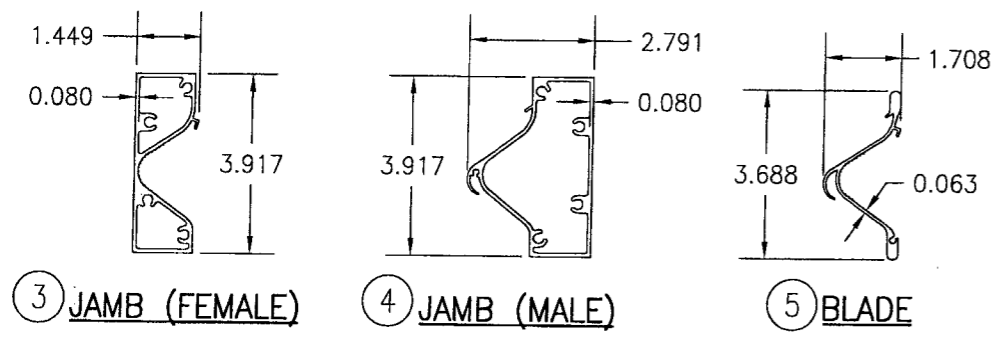

Approved as complying with the Florida Building Code  
 Date 02/04/2009  
 NOAH 02-17202.03  
 Miami Dade Product Control  
 Division  
 By

DRAWING TITLE  
EAV-81 IMPACT LOUVER SYSTEM

MANUFACTURER  
ARROW UNITED INDUSTRIES  
314 RIVERSIDE DRIVE  
WYALUSING, PA 18853  
570-746-1888

CONSULTANTS  
W. W. SCHAEFER ENGINEERING & CONSULTING, P.A.  
8895 N. MILITARY TRAIL, SUITE C-204  
PALM BEACH GARDENS, FL 33410  
PHONE: 561-775-4902 FAX: 561-775-4903

CERTIFICATION  
NOV 24 2008  
WARREN W. SCHAEFER, P.E.  
P.E. NO. 44135

DRAWING NO. 1624  
SHEET NO. 3 OF 3