

ARROW

OPERATORS FOR LOUVERS AND DAMPERS

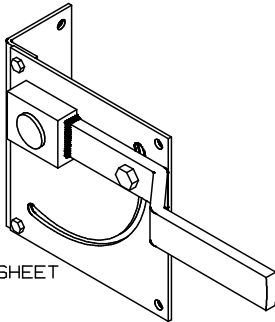

(SEE SHEET #440)

SPECIAL HEAVY-DUTY
MANUAL LOCKING QUADRANT
FOR USE WITH:
1/2" SHAFT UP TO 40 SQ. FT.
NO. Q-168-A
JACKSHAFTING, UP TO 80 SQ. FT.
NO. Q-168-B

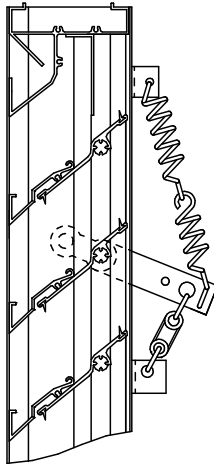

NO. O-21
SPRING OPERATED
WITH FUSIBLE LINK
(160° F)

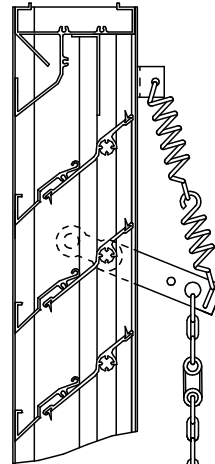

NO. O-18
CHAIN
OPERATED
SPRING
CLOSURE
8' CHAIN AND
FUSIBLE LINK
(160° F)

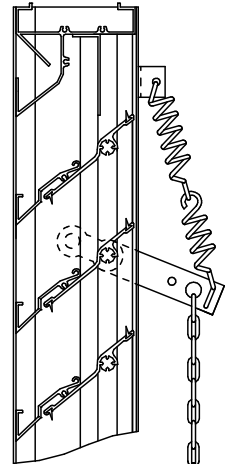

NO. O-17
CHAIN
OPERATED
SPRING
CLOSURE
WITH 8' CHAIN
AND WALL KEEPER

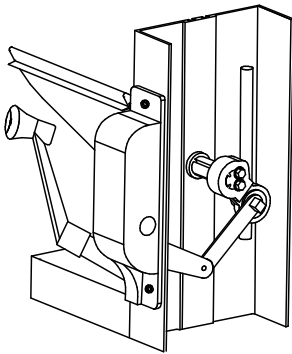

NO. O-25
HAND OPERATED CRANK
FOR UNITS UP TO 32 SQ. FT.
(SEE SHEET #759)

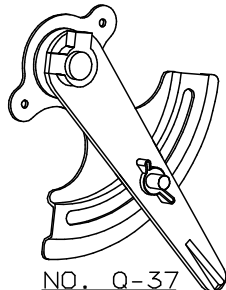

NO. Q-37
MANUAL LOCKING QUADRANT
FOR USE ON UNITS UP TO
24 SQ. FT. (DUCT MOUNTED)

NO. Q-38
MANUAL LOCKING QUADRANT
WITH PLATE FOR MOUNTING
IN CHANNEL FRAME

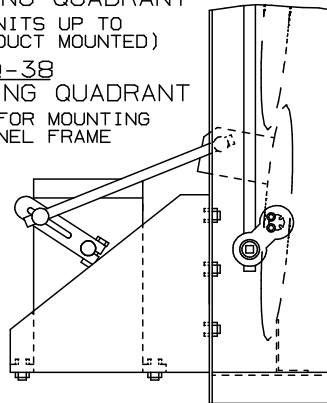

TYPICAL DAMPER DRIVE

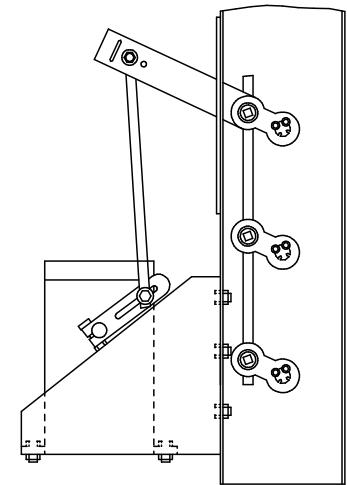

TYPICAL LOUVER DRIVE

(SEE SHEET #538)

MOTORS MAY BE MOUNTED FOR EXTERNAL OR
INTERNAL DRIVE (ABOVE ARE INTERNAL)

SPECIFY OPERATOR AND WHETHER N.O. OR N.C.

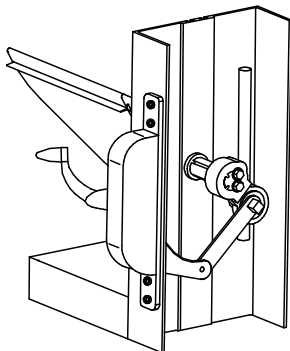

NO. O-24
HAND OPERATED CRANK
FOR UNITS UP TO 10 SQ. FT.
(SEE SHEET #759)

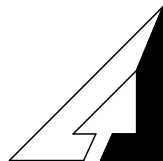

ARROW UNITED INDUSTRIES
A DIVISION OF MESTEK, INC.

314 RIVERSIDE DRIVE
WYALUSING, PA 18853

TEL: (570) 746-1888 FAX: (570) 746-9286
WEB ADDRESS: WWW.ARROWUNITED.COM

AGENT: _____